

DIRECTIONAL CONTROL VALVES– CETOP 03 proof II 2 GD, Ex d IIC T5

HD3-EX-*

40 l/min 25 MPa (250 bar)

1 DESCRIPTION

Valves HD3-EX are ATEX directional control valve solenoid operated with subplate mounting interface acc. to ISO 4401, DIN 24340 (CETOP 03).

The design of the body is an high quality five chamber casting. The valve is available with ATEX metallic DC and AC solenoids. In the standard version, the valve housing is phosphated for 240 h salt spray protection acc. to ISO 9227 . Enhanced surface protection for specific applications is available (ISO 9227, 520 h salt spray).



2 ORDERING CODE

(1)	(2)	(3)	(4)	(5)	(6)
HD3	-	EX	-	-	/ 25

(1) HD3 : 4-way directional valve Cetop 03 – Pressure 25 Mpa (250 bar)

(2) EX : electrically controlled, Ex-proof solenoid

(3) Spool type (see 4):

-number is the main spool type

-letter is the solenoid or spring arrangement:

C : 2 solenoids spool is spring centered (3 position)

N : 2 solenoids spool is detented (2 position) see 9

LL : 1 solenoid (a), spool is spring offset (2 position, end to end)

ML: 1 solenoid (a), spool is spring offset (2 position, middle to end)

LM: 1 solenoid (a), spool is spring offset (2 position, end to middle)

(4) Code reserved for option and variants

b: only for LL, ML, LM sol. b installed (instead of sol. a)

S-**: calibrated orifice on P port, see 10

ZT: zinc trivalent plated valve, see 11

(5) Electric voltage and solenoid coils

012C: coil(s) for V12DC

024C: coil(s) for V24DC

110A: coil(s) for V110/50 – V115/60 AC

230A: coil(s) for V220/50 – V230/60 AC

(6) Design number of the valves Atex solenoid for G and D

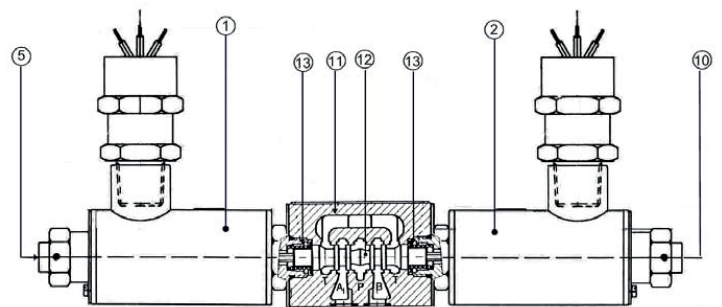
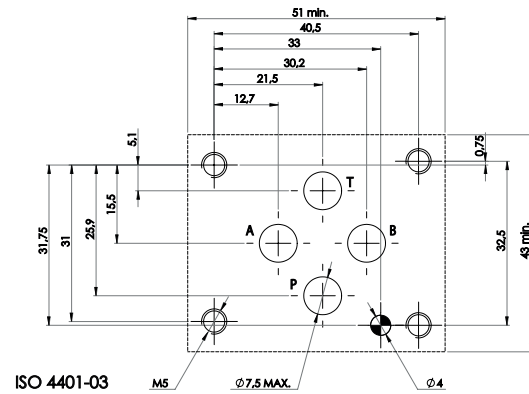

The spool 12 shifts into the valve body 11 subject to the action of springs 13 and solenoids 2. Spool 12, depending from its shape and its position in the valve body, opens and/ or closes passages between P, A, B and T ports, thus controlling the direction of the hydraulic flow.

3 TECHNICAL DATA

Nominal flow	32 l/min	Electric Characteristics: Valves type HD3-EX-* are operated by solenoid that are energized: • directly from a D.C. voltage supply: V 12 DC = 012 C V 24 DC = 024 C • by the use of coils that incorporate a full wave bridge rectifier, from A.C. voltage supply: V 110/50-V 115/60 = 110 A V 220/50-V 230/60 = 230 A Other voltages are available. Permissible supply voltage variation: + 5%. Ex-proof solenoid according to ATEX 94/9/EC, (II) 2GD, class Exd IIC T5 – see 7 Power consumption: max 11 w. Currents are, at nominal voltage and at 25°C: V12DC = 0,92A V115AC = approx 0,1A V24DC = 0,46A V230AC = approx 0,05A
Maximum rec. flow rate	40 l/min	
Maximum nominal pressure (P,A,B)	25 MPa (250 bar)	
Maximum pressure at T port	25 MPa (250 bar)	
Pressure drops	See 5	
Protection to DIN 40050	IP 67	
Duty cycle	100%	
Service life	≥ 10 ⁷ cycles	
Dimensions and Installation	see 6	
Mass	Approx 2,6 / 3,7 kg	

4 SPOOL IDENTIFICATION AND INTERMEDIATE POSITION TRANSITORIES

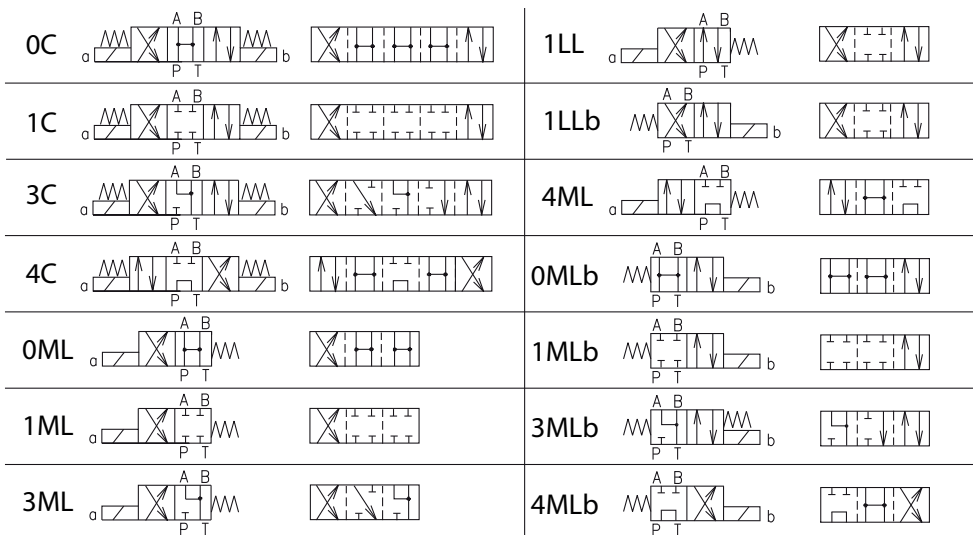

Spools, springs and solenoids combination permit to obtain almost every type of ports (P, A, B, T) connection and sequence. For almost all types of solenoids/springs combination and for all type of spools (with the exceptions of spool 4), when solenoid “a” is energized, hydraulic connections are P-> B and A ->T; to obtain P -> A and B-> T solenoid “b” must be energized. The hydraulic connections that are obtained in the “central” (neutral) position when solenoids are not energized is the characteristic mark of the spool shape and from it derives its identification number:

- 0 = P, A, B, T connected
- 1 = P, A, B, T closed
- 3 = P closed, A, B, T, connected.

5 TYPICAL DIAGRAMS

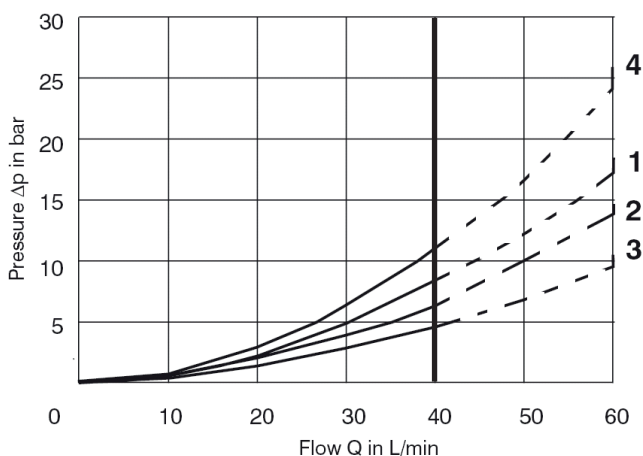

	P-A	P-B	A-T	B-T	P-T
1C	2	2	2	2	-
4C	4	4	4	4	2
0C	2	2	3	3	2
3C	2	2	3	3	-
1LL	3	3	4	4	-
1LLb	3	3	4	4	-
1ML	-	2	2	-	-
4ML	4	-	-	4	2
0ML	2	-	-	3	2
3ML	2	-	-	2	-

6 INSTALLATION DIMENSIONS

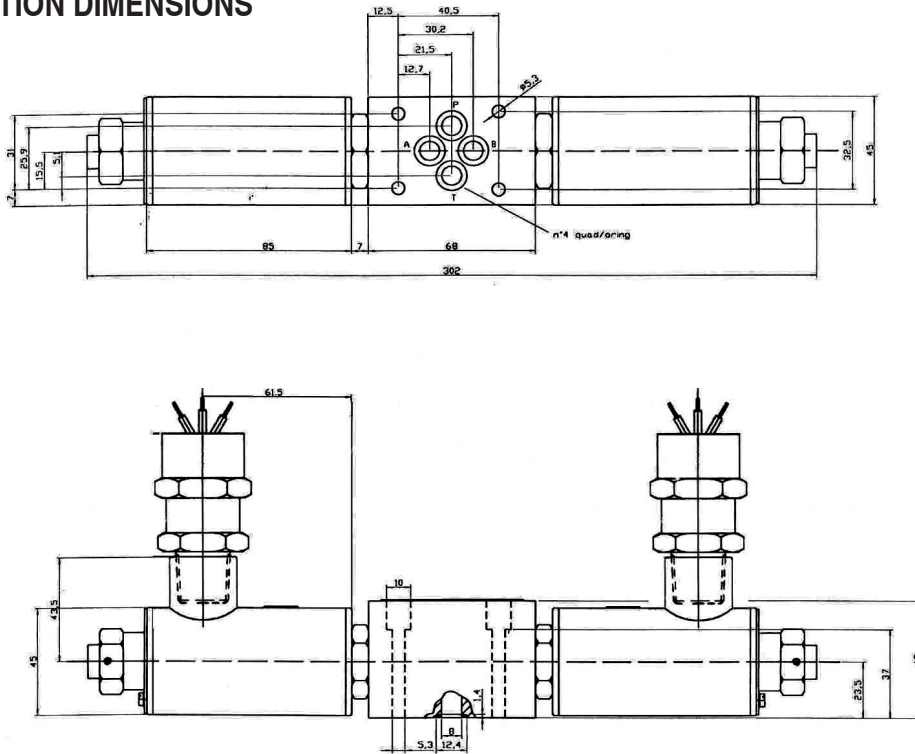

All valves HD3-* conform with ISO and CETOP specifications for mounting surface dimensions (see also front page) and for valves height. When assembled to its mounting plate valve HD3-* must be fastened with 4 bolts M5 X 45 mm (or M5 x ** according to the number of modules) tightened at 8 Nm torque. Leakage between valve and mounting surface is prevented by the positive compression on their seats of 4 seals of QUAD/O Ring type 9,25x1,68x1,68.

7 EXPLOSION PROOF SOLENOID GMA-6/HD SERIES 271 GD

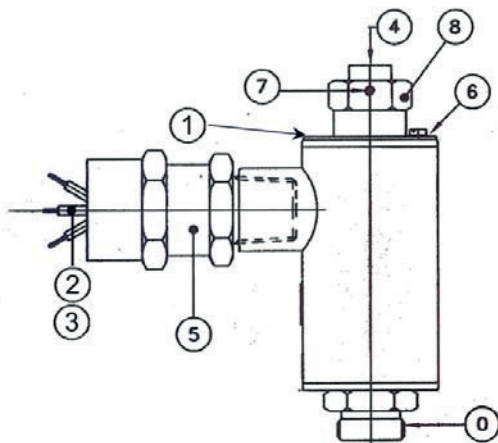

0: Ex proof solenoid according to ATEX 94/9/EC.
II 2GD Exd IIC T5.

Solenoid outside surfaces are zinc-nickel plated, with 7 minimum thickness
1: Solenoid label indicates supply voltage, protection class Exd, certification number by INERIS and maximum absorbed power.

2: 3-wires cable, according to CEI 20-22, of standard length of 1,5 m, is fastened to the coil and locked by cable gland.

3: Wires have 1,5 mm² section; earth connection wire is green-yellow. Electric connection must be in accordance with Ex-proof norm ATEX.

4: Manual override operation is by pushing the extended pin.

5: Normalised cable gland –torque 8 Nm + 1 – device has threaded attachment ½" conical – ISO 7/1

6: Earth connection screw

7: Threaded plug (socket hexagon 1,5 mm) to lock the retaining coil nut

8: Nut for retaining the coil –torque 6 Nm + 1 – hexagon 24 mm.

Conformity of unit to the norms is not granted if coil is used separately from its electromagnetic tube.

Atex Certificates :
INERIS 05ATEX0028X/02 for Gas and Dust

8 HYDRAULIC FLUIDS

Seals and materials used on standard valves HD3-* are fully compatible with hydraulic fluids of mineral oil base, upgraded with antifoaming and anti-oxidizing agents. The hydraulic fluid must be kept clean and filtered to ISO 4406 class 19/17/14, or better, and used in a recommended viscosity range from 10 cSt to 60 cSt.

9 VERSION "N": MECHANICAL DETENT ON SPOOL

Solenoid valves with detent typically are 2 position, 2 solenoid, nospring valve where the spool is kept at the extreme ends of its stroke by a mechanical device. This permits that solenoids are energized by short time current pulses and that the spool remains at its position regardless of forces due to hydrodynamics or gravitational/inertial effects (vibrations).

10 VERSION "S*": CALIBRATED ORIFICE ON P PORT

Option "S*" is represented by elements , suitably shaped to be inserted on P port of the solenoid valve, having a calibrated orifice (of various sizes) able to restrict, at the requested P value, the flow rate entering the solenoid valve. Those elements have the following orifice diameter:

3S - 10 $\varnothing D = 1 \text{ mm}$

3S - 20 $\varnothing D = 2 \text{ mm}$

3S - 25 $\varnothing D = 2,5 \text{ mm}$

and are kept sealed on the P port of the valve by an OR of 9,25x1,78 mm sizes (example OR 110 - 2037).

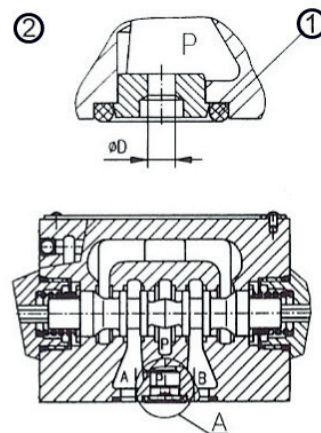

11 VERSION "ZT": ZINC PLATED VALVES

Solenoid valves according to "ZT" version have central body zinc trivalent plated and protected against every type of corrosion due to saline ambiance or other aggressive chemicals. Zinc thickness are on the valve body: 10-15 μm .

PROPORTIONAL 4-WAY CONTROL VALVES Ex - proof II 2 GD, Ex d IIC T5

HD3-PX

32 l/min 25 MPa (250 bar)

1 DESCRIPTION

Valves HD3-PX are ATEX proportional directional control valve with subplate mounting interface acc. to ISO 4401, DIN 24340 (CETOP 03). The design of the body is an high quality five chamber casting. The valve is available with ATEX metallic DC and AC solenoids. In the standard version, the valve housing is phosphated for 240 h salt spray protection acc. to ISO 9227. Enhanced surface protection for specific applications is available (ISO 9227, 520 h salt spray).



2 ORDERING CODE

(1)	(2)	(3)	(4)	(5)	(6)	(7)
HD3	-	PX	-	-	-	/

(1) HD3: : 4-way directional valve Cetop 03 – Pressure 25 Mpa (250 bar)

(2) PX : Proportional electric control, Ex-proof solenoid (see 7)

(3) Functional spool type (see 5)

- number:

1 : closed center (P, A, B, T blocked)

3 : P blocked, A, B, T connected

-spool nominal flow:

P : 32 l/min with P = 1 Mpa (10 bar) (PA+BT or PB+AT)

R : 16 l/min with P = 1 Mpa (10 bar) (PA+BT or PB+AT)

05 : 05 l/min with P = 1 Mpa (10 bar) (PA+BT or PB+AT)

D : differential $Q_b = 2Q_a$: 32/16 l/min with P = 1 Mpa (10 bar)

(4) Solenoids and springs arrangements (see 5)

C : 2 sol., spool is springs centered

ML : 1 sol. ("a") spool is centered + 1 end position

MLb : 1 sol. ("b") spool is centered + 1 end position

(5) Options and variants

ZC : zinc plated valves (see 10)

(6) Type of coil(s) and supply voltages (see 7)

R2 : standard V12DC (R=11,3)

R4 : standard V24DC (R=45,3)

(7) Design number (progressive) of the valve.

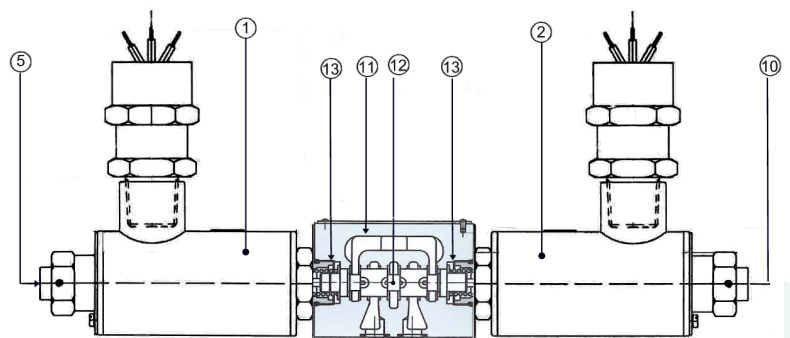
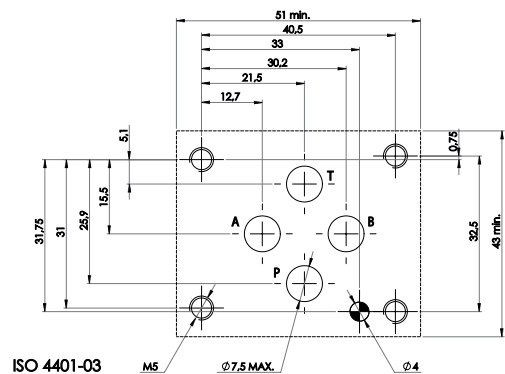

The spool 12 shifts in to the valves body 11 subject to the action of springs 13 and proportional solenoids 1 and 2. Spool 12, depending from its shape and its position in the valves body 11, opens and/or closes passages between P, A, B, T ports, thus controlling the direction and the rate of the hydraulic flow. Solenoids 1 and 2 are energized by electric current flowing-in through cables; in case of electric cut-offs, the spool can be manually shifted by acting on the emergency pins, located at the end of the solenoids and accessible through the retaining nuts.

3 TECHNICAL DATA

Nominal flow rates	5, 16, 32 l/min	Electric characteristics:
Maximum nominal pressure (P,A,B)	25 Mpa (250 bar)	Valves type HD3-PX-* are valves operated by Ex-proof proportional solenoids ATEX qualified for class EExd IIc T5 – see 9.
Maximum pressure at T port	25 Mpa (250 bar)	On valves type HD3-PX-*, the max permissible power consumption on each solenoid is 11w and, therefore, the currents to solenoids have to be limited to:
Maximum rec. Pressure drops	5 Mpa (50 bar) (see 5)	• I max = 0,92 A for coils R2 (R=11,3)
Protection to DIN 40050	IP 67	• I max = 0,46 A for coils R4 (R=45,3)
Duty cycle	100%	Currents to hydraulic proportional valves are normally supplied by an electronic driver based on PWM mode of operation, capable of full control of min and max values of current – see 14.
Service life	> 10 ⁷ cycles	
Dimensions and installation	(see 8)	
Mass	Approx 2,6 / 3,7 kg	

4 TYPICAL DIAGRAMS

Typical flow curves of valves HD3-PX-* in standard configuration measured with mineral oil at 36 cSt and at 50°C at ΔP=01 Mpa (10 bar) for flow P → B, A → T

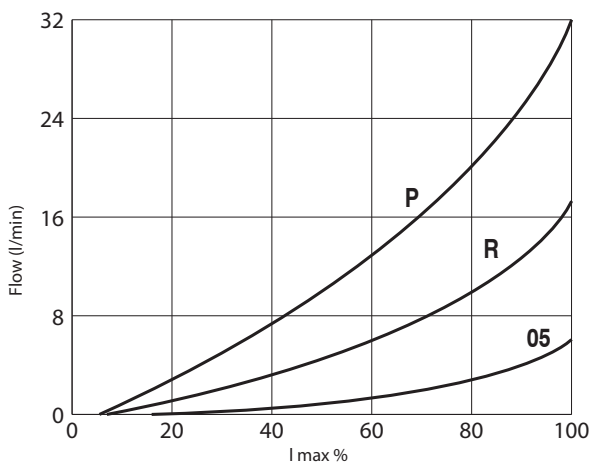

6 FLOW RATES AND PRESSURE DIFFERENTIAL

For a given ΔP on a given valve the flow rates are proportional to the driving current (see 4); for a given driving current on a given valve, the flow rates increase with the increasing of the ΔP up to certain limits. Typical limit curves are:

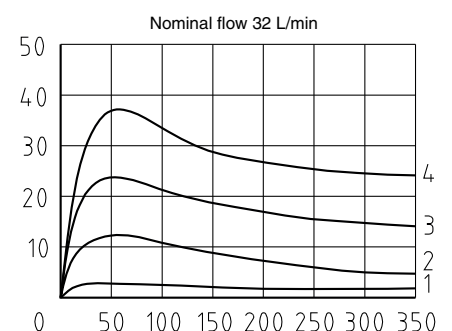
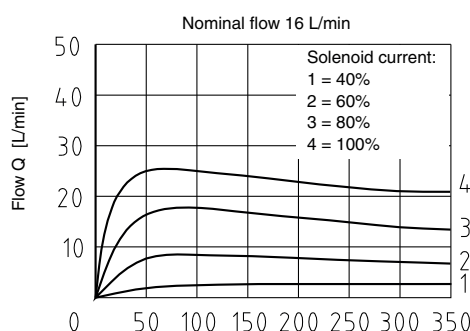
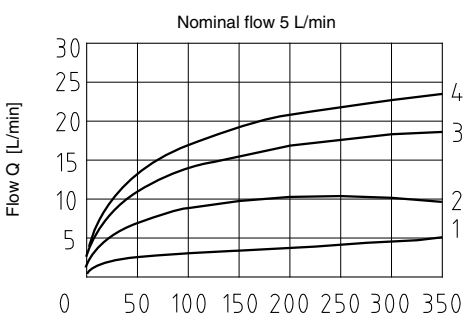

5 SPOOL IDENTIFICATION AND INTERMEDIATE POSITION TRANSITORIES

Nominal Flow rate 5 l/min

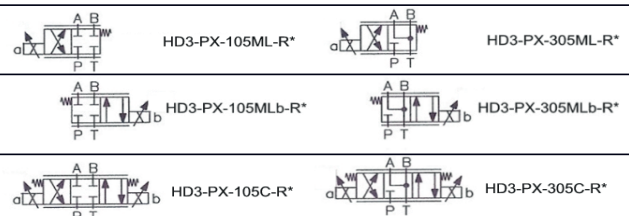

Nominal Flow rate 16 l/min

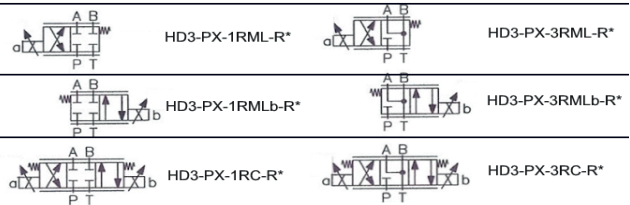

Nominal Flow rate 32 l/min

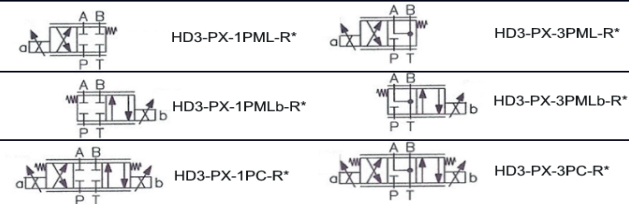

Differential flow: Q_b=2Q_a (example P→B=32 l/min and A→T= 16 l/min)



7 EXPLOSION PROOF SOLENOID TYPE GMA-6/PX SERIES 271

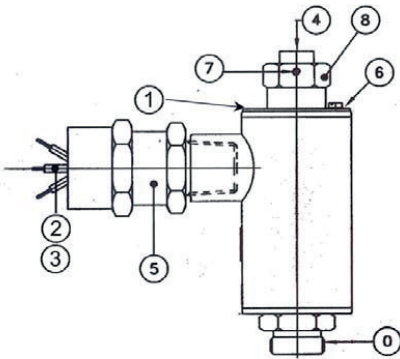

0: Ex proof solenoid according to ATEX 94/9/CE.

Class EX II 2G EExd IIC T5.

Solenoid outside surfaces are nickel plated, with 7 minimum thickness

1: Solenoid label indicates supply voltage, protection class EExd, certification number by INERIS and maximum power.

2: 3-wires cable, according to CEI 20-22, of standard length of 1,5 m, is fastened to the coil and locked by cable gland 5.

3: Wires have 1,5 mm² section; earth connection wire is green-yellow.

Electric connection must be in accordance with Ex-proof norm ATEX.

4: Manual override operation is by pushing the extended pin.

5: Normalised cable gland –torque 8 Nm + 1 – device has threaded attachment ½” conical – ISO 7/1

6: Earth connection screw

7: Threaded plug (socket hexagon 1,5 mm)to lock the retaining coil nut

8: Nut for retaining the coil –torque 6 Nm + 1 – hexagon 24 mm.

Conformity of unit to the norms is not granted if coil is used separately from its electromagnetic tube.

8 INSTALLATION DIMENSIONS (mm)

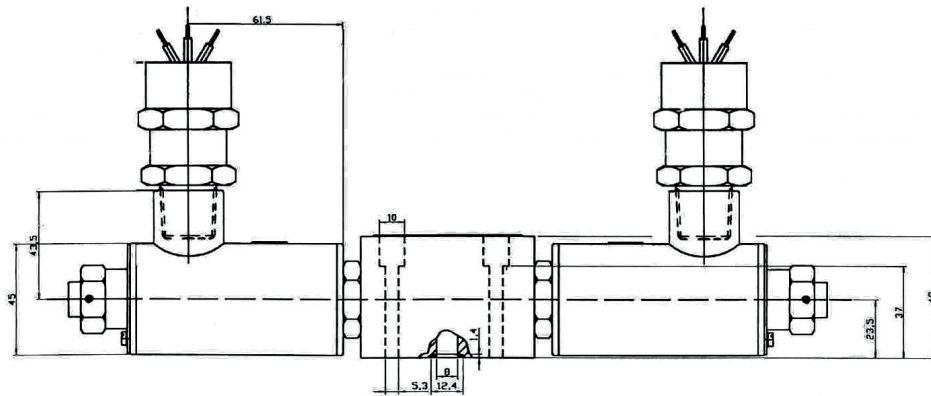
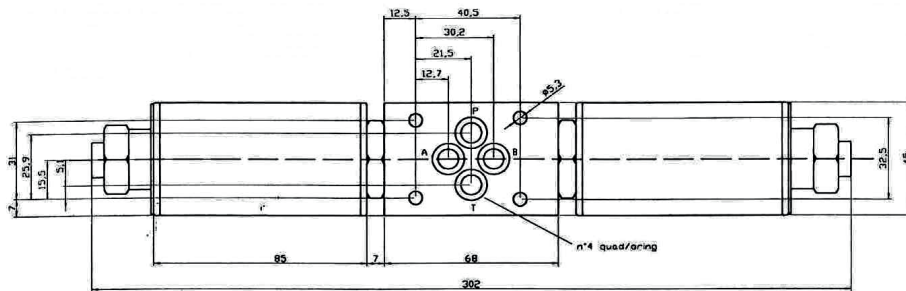

All valves HD3-* conform with ISO and CETOP specifications for mounting surface dimensions (see also front page) and for valves height. When assembled to its mounting plate valve HD3-* must be fastened with 4 bolts M5 X 45 mm (or M5 x ** according to the number of modules) tightened at 8 Nm torque. Of special interest is the mounting of pressure compensator modules with HD3-P proportional valves – see 15. Leakage between valve and mounting surface is prevented by the positive compression on their seats of 4 seals of QUAD/O Ring type 9,25x1,68x1,68.

9 HYDRAULIC FLUIDS

Seals and materials used on standard valves HD3-* are fully compatible with hydraulic fluids of mineral oil base, upgraded with antifoaming and anti-oxidizing agents. The hydraulic fluid must be kept clean and filtered to ISO 4406 class 19/17/14, or better, and used in a recommended viscosity range from 10 cSt to 60 cSt.

10 VERSION "ZC": ZINC PLATED VALVES

Solenoid valves according to "ZC" version have central body zinc plated and protected against every type of corrosion due to saline ambience or other aggressive chemicals. Zinc thickness are on the valve body: 10-15 μ m.

11 PRESSURE COMPENSATOR MODULES

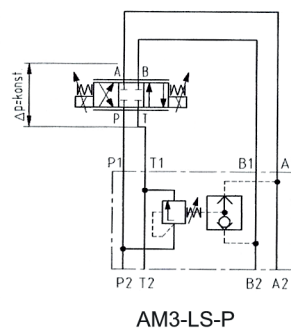
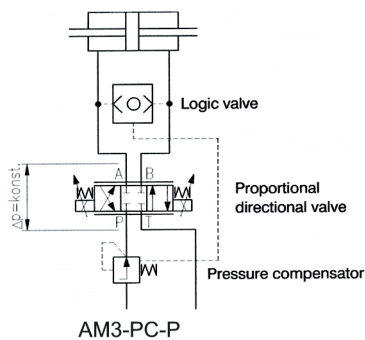

2-way pressure compensator for meter-in application type AM3-PCP – see table AM-391. When using the 2-way pressure compensators in meter-in application, shown in the circuit diagram, a constant pressure difference across the metering edge of the proportional direction valve is held. In this case, the pressure variations due to loading changes, as well as pump pressure changes, are compensated. That means that a pressure change cannot result in flow increase. 3-way pressure compensator type AM3-LS-P is able to operate as "load sensing" device, by discharging at T port, at the same pressure of the user, the flow that exceeds the flow rates required by the controlled opening of the proportional 4-way valve.

DIRECTIONAL CONTROL VALVES - proof II 2 GD, EEx d IIC T5

HD5-EX

150 l/min 32 MPa (320 bar)

1 DESCRIPTION

HD5-EX-** Ex proof electrically are pilot operated 4 way valves of size ISO 05 with mounting surface according to Cetop 4.2-4 P05-320
 Characteristics of the Ex proof, electrically operated, pilot valve type HD3-EX-** are described on Aidro table HD-3EX rev.

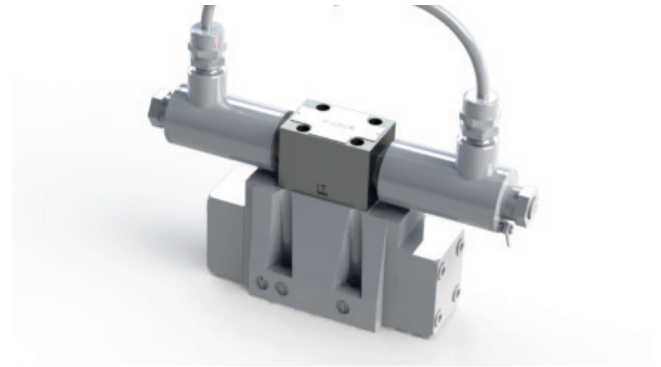

2 ORDERING CODE

(1)	(2)	(3)	(4)	(5)	(6)	(7)	(8)
HD5	-	EX	-	-	-	-	/ 40

(1) HD5: 4-way directional control valve Cetop 05- Pressure 32 MPa (320 bar)

(2) Variants:

- EX: electrically controlled, EX Proof ATEX
- HH: hydraulically piloted (main body)

(3) Spool type:

- number is the main spool type
- letter is the solenoid or spring arrangement:
 - C : 2 solenoids, spool is spring centered (3 position)
 - LL : 1 solenoid (a), spool is spring/hydr. offset (2 position, end to end)
 - ML: 1 solenoid (a), spool is spring offset (2 position, middle to end)
 - LM: 1 solenoid (a), spool is spring offset (2 position, end to middle)
- b: only for versions LL, ML, LM see also functional symbols

(4) Location of X and Y ports.

- no designation: standard, according to CETOP 4.2-4 P05-320
- R05: according to CETOP 4.2-4R05-320 and ISO/ CD 4401-05

(5) Code reserved for options and variants

- C: adjustable limits for main spool stroke
- D: double flow control valve to adjust shifting speed
- G: adjustable limits and adjustable shifting speed

(6) Pilot and drain arrangement

- no designation: internal pilot and external drain (standard)
- I : internal pilot and internal drain
- E: external pilot and external drain

(7) Electric voltage and solenoid coils

- 012C : coils for V12DC
- 024C : coils for V24DC
- 115A : coils for V110/50 - V 115/60 AC
- 230A : coils for V220/50 - V 230/60 AC
- See also electric characteristics

(8) Design number (progressive) of the valves

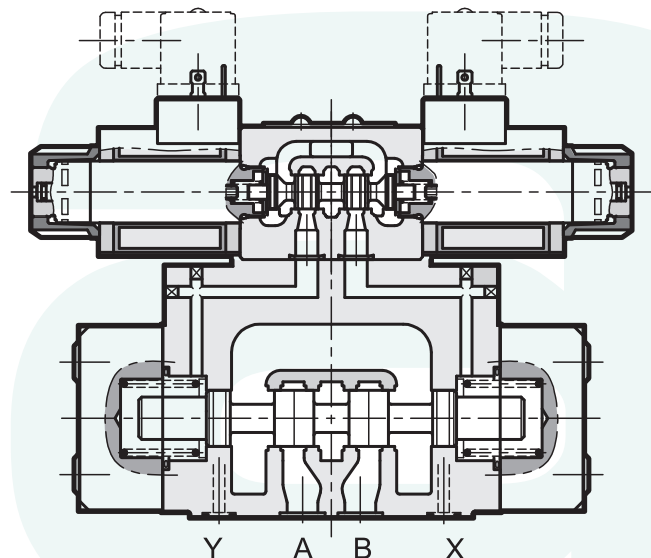
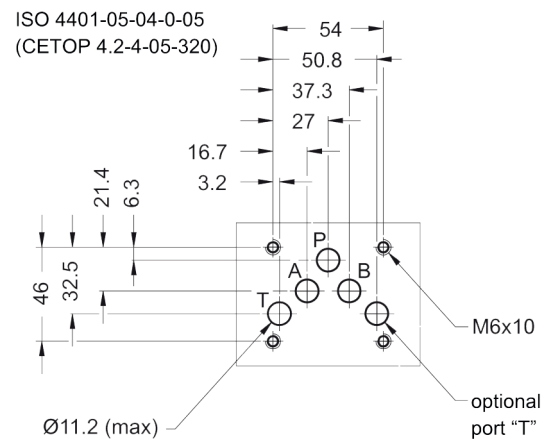

3 TECHNICAL DATA

max recommended flow (spring centering)	150 l/min	Note: When valves HD5-EX-** are made with internal pilot and internal drain ("I" configuration), ports X and Y are not used and valves can be installed on normal 05 surface mounting plates according to ISO 4401-05.
Maximum pressure (P,A,B)	32 MPa (320 bar)	
Maximum pressure at T port (internal drain)	16 MPa (160 bar)	
Maximum pressure at T port (external drain)	25 MPa (250 bar)	
Pilot pressure minimum	0,5 MPa (5 bar)	
Pilot pressure maximum recommended	20 MPa (200 bar)	
Dimensions and installation	see 6	
Mass	Approx 9,00/10,2 kg	

4 PRESSURE DROP

Δp -Q
Measured at $v = 166$ SUS (35 mm²/s) and $t = 122$ °F (50 °C)

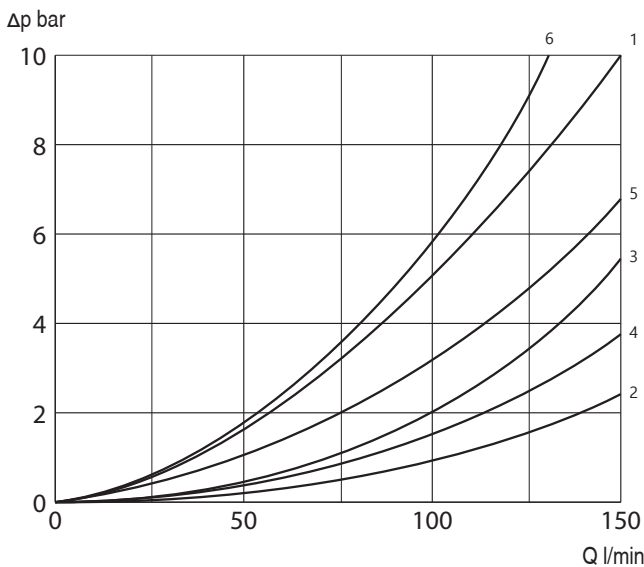

5 SPOOL IDENTIFICATION AND INTERMEDIATE POSITION TRANSITORIES

Three positions with spring centering

1C		
0C		
3C		
4C		

Two positions with return spring

1LL		
0LL		
1ML		
1LLb		
0LLb		
1MLb		

Three positions with spring centering - special spools

77C		
56C		
8C		
76C		

6 INSTALLATION DIMENSIONS (mm)

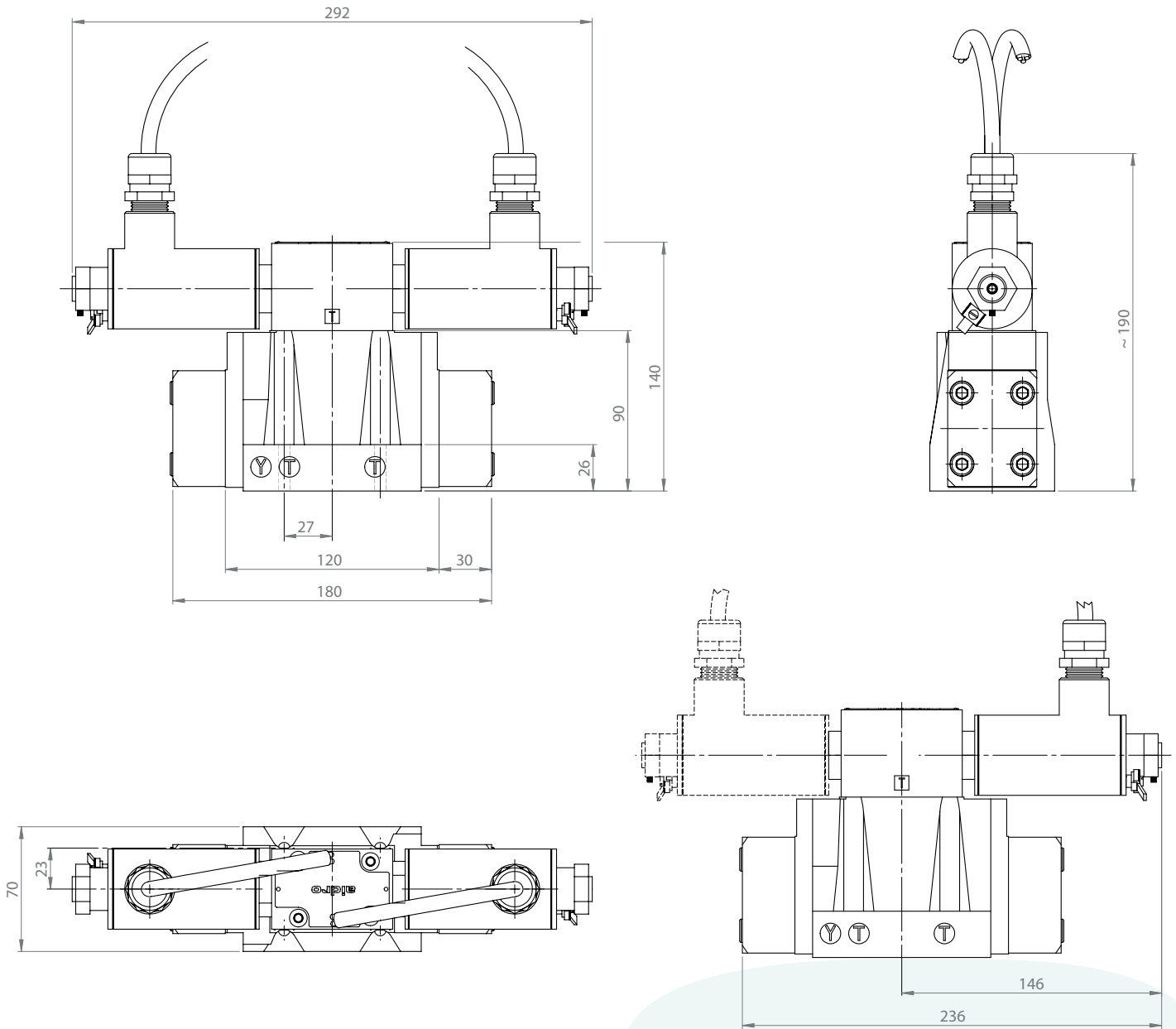



Spool type	Spool position	Connections				
		P-A	P-B	A-T	B-T	P-T
		Curves on graph				
1C	Energized	1	1	2	3	
0C	De-energized					6*
	Energized	5	5	1	2	
3C	De-energized			4*	4°	
	Energized	1	1	1	2	
4C	De-energized					6
	Energized	6	6	3	4	
1LL,0LL	De-energized	1			3	
1ML	Energized		1	2		
77C	De-energized				4	
	Energized	1	1	2	2	
56C	De-energized					6*
	Energized	6	6	4	3	
8C	De-energized	4*	4°			
	Energized	5	5	2	3	
76C	De-energized			3		
	Energized	1	1	1	3	

* A-B blocked

· B blocked

° A blocked

Control of the main spool stroke: C

It is possible to introduce special stroke controls in the heads of the hydropiloted valve so as to vary the maximum spool stroke. This solution allows control of the flow rate from the pump to the actuator and from the actuator to the outlet, obtaining a double adjustable control on the actuator. Add the letter **C** to the identification code to request this device.

Control of the main spool shifting speed: D

By placing a double flow control valve between the pilot solenoid valve and the hydropiloted valve, the piloted flow rate can be controlled and therefore the shifting speed can be varied. Add the letter **D** to the identification code to request this device.

Control of the main spool stroke and shifting speed: G

It is possible to have the valve fitted with both the spool stroke device and the piloting flow rate control device. Add the letter **G** to the identification code to request this solution.